

RoHS
COMPLIANT

Step 1: Place Housing into PE bag and seal PE bag. Label.
将 Housing放入PE袋内, 并将PE袋封好, 贴上标签。

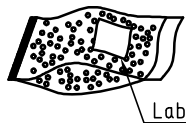

Step 2: Put PE bag packed products in cartons,
Packing detail see the table right
将装好产品的PE袋放入纸箱内, 详细包装见右表

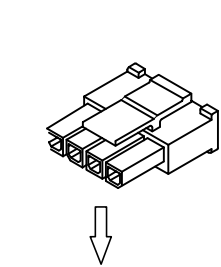
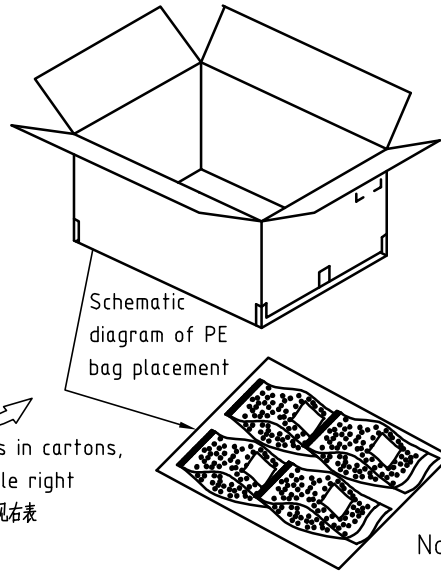

Step 3: Put PE bag packed products in cartons,
Packing detail see the table right
将装好产品的PE袋放入纸箱内, 详细包装见右表

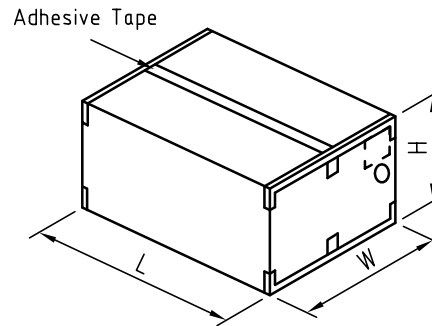

Circuits	PCS/Bag
2	1000
3	1000
4	1000
5	1000
6	1000
7	1000
8	1000
9	1000
10	500
11	500
12	500

	SPEC.	Remark
Carton 1	L460mm×W460mm×H510mm	Use the appropriate carton size according to the actual order quantity 根据实际订单数量使用合适的纸箱尺寸
Carton 2	L500mm×W500mm×H305mm	
Carton 3	L580mm×W580mm×H320mm	

Note注解:

1. There shall be no dirt such as deformation phenomenon, Mantissa box fillers must be used
每箱不可有脏污, 变形现象, 尾数箱必须用填充物
2. Confirm whether the inner and outer labels are missing and the content must be consistent with the actual product
确认内外标签有无漏失, 内容与实物必须一致
3. Packing quantity per carton depends on order and delivery quantity
每箱包装数量依订单及交货数量而定

F					TOLERANCE	TITLE:	DRAWN: Arvin 2020.03.05	KONNRA 东莞市康瑞电子有限公司			
					X. X ±0.30	MX3.0 Male Housing Single Row Package specification	CHECKED:	DongGuan Konnra Electronics Co., Ltd.			
					X. XX ±0.20		APPROVED:	PART NO.: H3000M****01A			
MARK	REVISION DESCRIPTION	SIGNATURE	DATE	X. XXX ±0.10	Angle ±2°	UNIT: mm	SCALE: N/A	SHEET: 1/1	PROJECTION	REV.: A1	DRAWING NO.: 3000HM01-A-P

1 2 3 4 5 6 7 8 9

RoHS
COMPLIANT

Step 1: Place Housing into PE bag and seal PE bag. Label.

将 Housing放入PE袋内，并将PE袋封好，贴上标签。

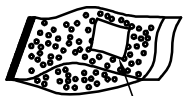
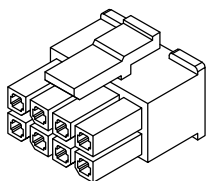

Label

Step 2: Put PE bag packed products in cartons, Packing detail see the table right

将装好产品的PE袋放入纸箱内，详细包装见右表

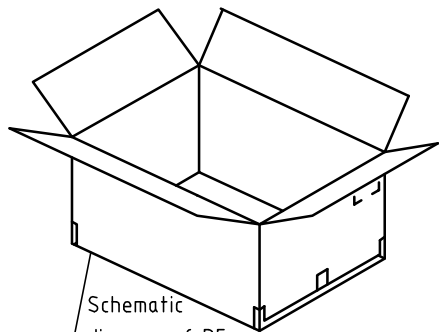

Schematic diagram of PE bag placement

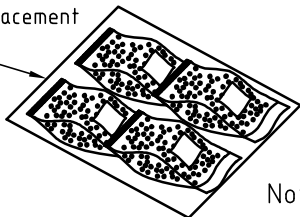

Adhesive Tape

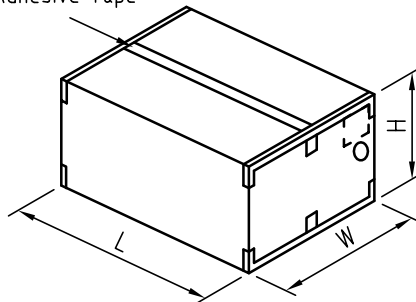

Circuits	PCS/Bag
2x1	1000
2x2	1000
2x3	1000
2x4	1000
2x5	1000
2x6	1000
2x7	1000
2x8	500
2x9	500
2x10	500
2x11	500
2x12	500

Note注解:

1. There shall be no dirt such as deformation phenomenon, Mantissa box fillers must be used
每箱不可有脏污，变形现象，尾数箱必须用填充物
2. Confirm whether the inner and outer labels are missing and the content must be consistent with the actual product
确认内外标签有无漏失，内容与实物必须一致
3. Packing quantity per carton depends on order and delivery quantity
每箱包装数量依订单及交货数量而定

	SPEC.	Remark
Carton 1	L460mm×W460mm×H510mm	Use the appropriate carton size according to the actual order quantity根据实际订单数量使用合适的纸箱尺寸
Carton 2	L500mm×W500mm×H305mm	
Carton 3	L580mm×W580mm×H320mm	



MARK

1

2

3

4

5

6

7

8

9

TOLERANCE

X. X ±0.30

X. XX ±0.20

X. XXX ±0.10

Angle ±2°

TITLE:
MX3.0 Male Housing
Dual Row Package
specification

UNIT: mm

SCALE: N/A

DRAWN: Arvin 2020.03.05

CHECKED:

APPROVED:

SHEET: 1/1

PROJECTION

KONNRA 东莞市康瑞电子有限公司
DongGuan Konnra Electronics Co., Ltd.

PART NO.: H3000M****01A

REV.: A1 DRAWING NO.: 3000HM201-A-P

RoHS
COMPLIANT

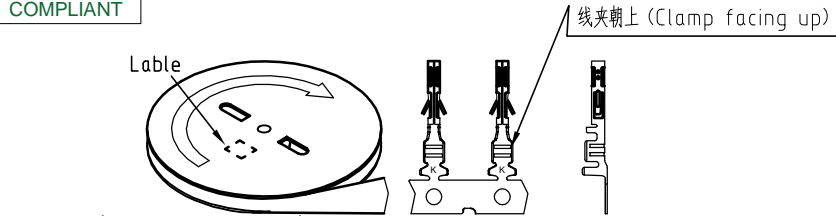

W=2.30(T3000FPxxx01A)

Package way

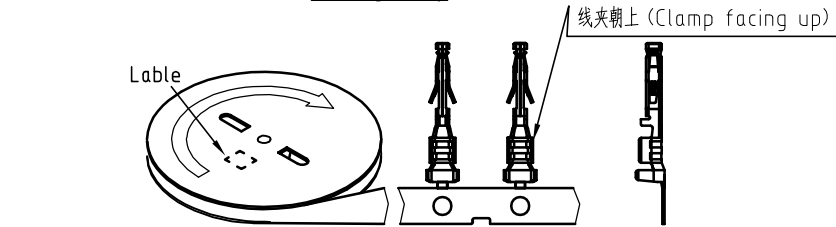

B Type(T3000FPxxx01C)

Package way

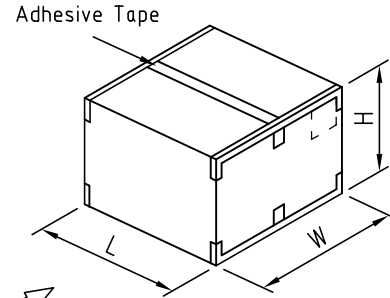
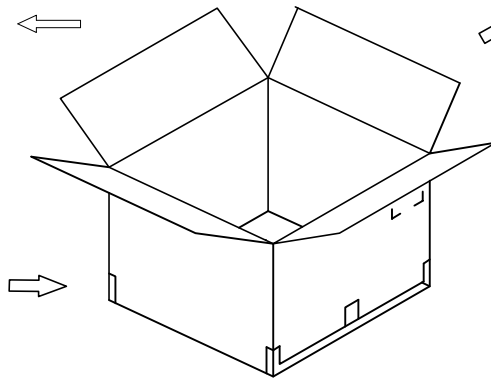
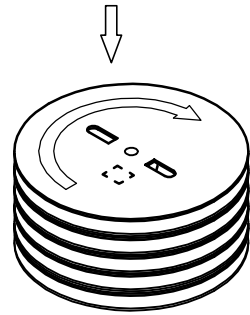

Note注解:

- There shall be no dirt such as deformation phenomenon, Mantissa box fillers must be used
每箱不可有脏污，变形现象，尾数箱必须用填充物
- Confirm whether the inner and outer labels are missing and the content must be consistent with the actual product
确认内外标签有无漏失，内容与实物必须一致
- Quantity(数量): 10K PCS/REEL (10K PCS/盘)
Packing quantity per carton depends on order and delivery quantity
每箱包装数量依订单及交货数量而定

	SPEC.	Remark
Carton 1	L460mm×W460mm×H510mm	Use the appropriate carton size according to the actual order quantity 根据实际订单数量使用合适的纸箱尺寸
Carton 2	L500mm×W500mm×H305mm	
Carton 3	L580mm×W580mm×H320mm	



MARK

1

2

3

4

5

6

7

8

9

TOLERANCE

X.X ±0.30

X.XX ±0.20

X.XXX ±0.10

Angle ±2°

TITLE:
MX3.0 Female
Terminal Package
Specification

UNIT: mm SCALE: N/A

DRAWN: Arvin 2020.03.05

CHECKED:

APPROVED:

SHEET: 1/1 PROJECTION

KONNRA 东莞市康瑞电子有限公司
DongGuan Konnra Electronics Co., Ltd.

PART NO.: T3000FP***01*

REV.: A1 DRAWING NO.: 3000TF101-A-P

RoHS
COMPLIANT

Step 1: Place Housing into PE bag and seal PE bag. Label.
将 Housing放入PE袋内, 并将PE袋封好, 贴上标签。

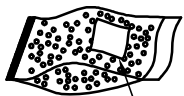
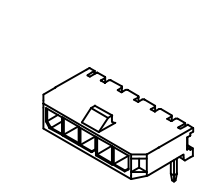

Label

Step 2: Put PE bag packed products in cartons,
Packing detail see the table right
将装好产品的PE袋放入纸箱内, 详细包装见右表

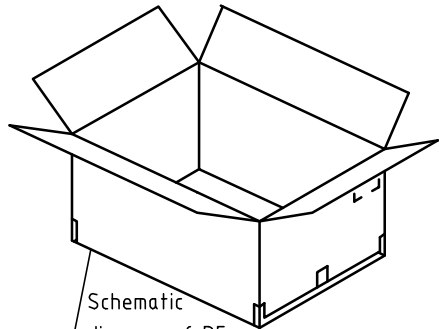

Schematic diagram of PE bag placement

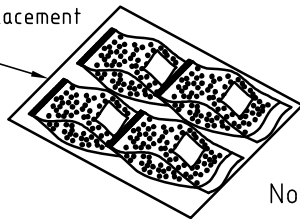

Adhesive Tape

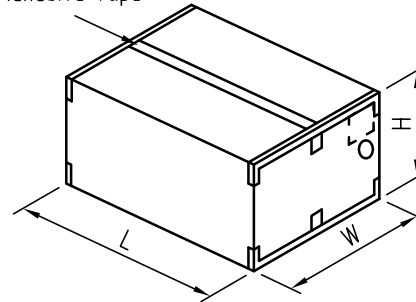

Circuits	PCS/Bag
2	1000
3	1000
4	1000
5	1000
6	500
7	500
8	500
9	500
10	500
11	500
12	500

Note注解:

1. There shall be no dirt such as deformation phenomenon, Mantissa box fillers must be used
每箱不可有脏污, 变形现象, 尾数箱必须用填充物
2. Confirm whether the inner and outer labels are missing and the content must be consistent with the actual product
确认内外标签有无漏失, 内容与实物必须一致
3. Packing quantity per carton depends on order and delivery quantity
每箱包装数量依订单及交货数量而定

	SPEC.	Remark
Carton 1	L460mm×W460mm×H510mm	Use the appropriate carton size according to the actual order quantity 根据实际订单数量使用合适的纸箱尺寸
Carton 2	L500mm×W500mm×H305mm	
Carton 3	L580mm×W580mm×H320mm	



MARK

1

2

3

4

5

6

7

8

9

TOLERANCE

X. X ±0.30

X. XX ±0.20

X. XXX ±0.10

Angle ±2°

TITLE:

MX3.0 DIP 180°

Wafer Single Row

Packing

UNIT: mm

SCALE: N/A

DRAWN: Arvin 2020.03.05

CHECKED:

APPROVED:

SHEET: 1/1

PROJECTION

KONNRA 东莞市康瑞电子有限公司

DongGuan Konnra Electronics Co., Ltd.

PART NO.: C300ORD1****T0101PA

REV.: A1

DRAWING NO.: 3000WRD101-A-P

RoHS
COMPLIANT

Step 1: Place Housing into PE bag and seal PE bag. Label.
将 Housing放入PE袋内, 并将PE袋封好, 贴上标签。

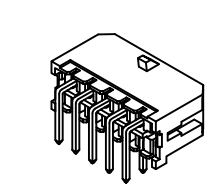

Label

Step 2: Put PE bag packed products in cartons,
Packing detail see the table right
将装好产品的PE袋放入纸箱内, 详细包装见右表

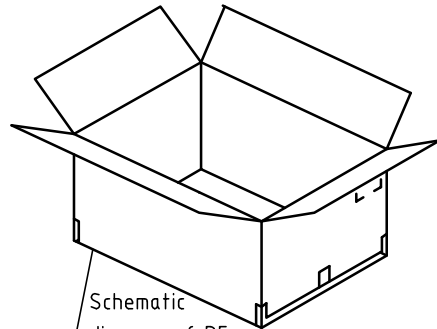

Schematic diagram of PE bag placement

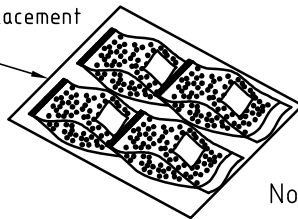

Adhesive Tape

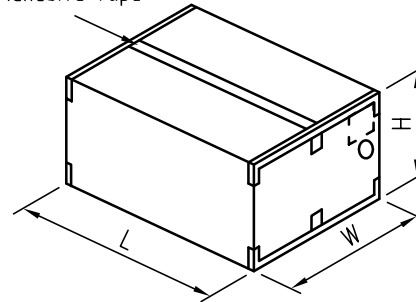

Circuits	PCS/Bag
2x1	1000
2x2	1000
2x3	1000
2x4	1000
2x5	500
2x6	500
2x7	500
2x8	250
2x9	250
2x10	250
2x11	250
2x12	250

Note注解:

1. There shall be no dirt such as deformation phenomenon, Mantissa box fillers must be used
每箱不可有脏污, 变形现象, 尾数箱必须用填充物
2. Confirm whether the inner and outer labels are missing and the content must be consistent with the actual product
确认内外标签有无漏失, 内容与实物必须一致
3. Packing quantity per carton depends on order and delivery quantity
每箱包装数量依订单及交货数量而定

	SPEC.	Remark
Carton 1	L460mm×W460mm×H510mm	Use the appropriate carton size according to the actual order quantity 根据实际订单数量使用合适的纸箱尺寸
Carton 2	L500mm×W500mm×H305mm	
Carton 3	L580mm×W580mm×H320mm	



MARK

1

2

3

4

5

6

7

8

9

TOLERANCE
X. X ±0.30
X. XX ±0.20
X. XXX ±0.10
Angle ±2°

TITLE:
MX3.0 DIP 90° Wafer
Dual Row Packing

DRAWN: Arvin 2020.03.05

CHECKED:

APPROVED:

UNIT: mm

SCALE: N/A

SHEET: 1/1

PROJECTION

REV. : A1

DRAWING NO. : 3000WRD201-A-P

KONNRA 东莞市康瑞电子有限公司
DongGuan Konnra Electronics Co., Ltd.

PART NO. : C3000RD2****T0101PA

RoHS
COMPLIANT

Step 1: Place Housing into PE bag and seal PE bag. Label.

将 Housing放入PE袋内, 并将PE袋封好, 贴上标签.

C3000VD1xxx×T0101PA

C3000VD1xxx×T0106PA

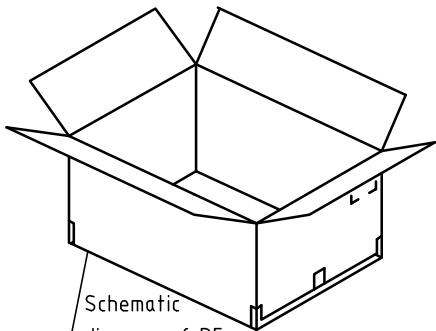
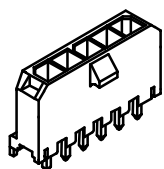
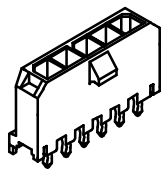

Schematic diagram of PE bag placement

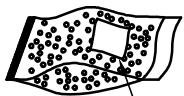

Label

Step 2: Put PE bag packed products in cartons, Packing detail see the table right

将装好产品的PE袋放入纸箱内, 详细包装见右表

Step 3: Put PE bag packed products in cartons, Packing detail see the table right

将装好产品的PE袋放入纸箱内, 详细包装见右表

Adhesive Tape

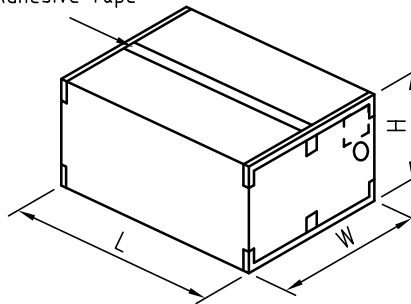

Circuits	PCS/Bag
2	1000
3	1000
4	1000
5	1000
6	1000
7	1000
8	500
9	500
10	500
11	500
12	500

Note注解:

1. There shall be no dirt such as deformation phenomenon, Mantissa box fillers must be used
每箱不可有脏污, 变形现象, 尾数箱必须用填充物
2. Confirm whether the inner and outer labels are missing and the content must be consistent with the actual product
确认内外标签有无漏失, 内容与实物必须一致
3. Packing quantity per carton depends on order and delivery quantity
每箱包装数量依订单及交货数量而定

	SPEC.	Remark
Carton 1	L460mm×W460mm×H510mm	Use the appropriate carton size according to the actual order quantity 根据实际订单数量使用合适的纸箱尺寸
Carton 2	L500mm×W500mm×H305mm	
Carton 3	L580mm×W580mm×H320mm	



MARK

1

2

3

4

5

6

7

8

9

TOLERANCE

X. X ±0.30

X. XX ±0.20

X. XXX ±0.10

Angle ±2°

TITLE:

MX3.0 DIP 180°

Wafer Single Row

Packing

UNIT: mm

SCALE: N/A

DRAWN: Arvin 2020.03.05

CHECKED:

APPROVED:

SHEET: 1/1

PROJECTION

KONNRA 东莞市康瑞电子有限公司

DongGuan Konnra Electronics Co., Ltd.

PART NO.: C3000VD1****T01**PA

REV.: A1

DRAWING NO.: 3000WD101-A-P

RoHS
COMPLIANT

Step 1: Place Housing into PE bag and seal PE bag. Label.
将 Housing放入PE袋内, 并将PE袋封好, 贴上标签。

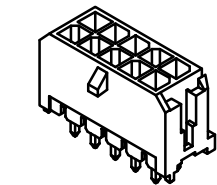

Label

Step 2: Put PE bag packed products in cartons,
Packing detail see the table right
将装好产品的PE袋放入纸箱内, 详细包装见右表

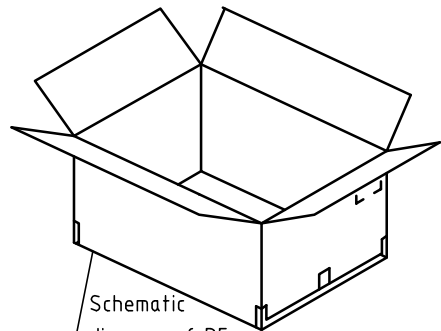

Schematic diagram of PE bag placement

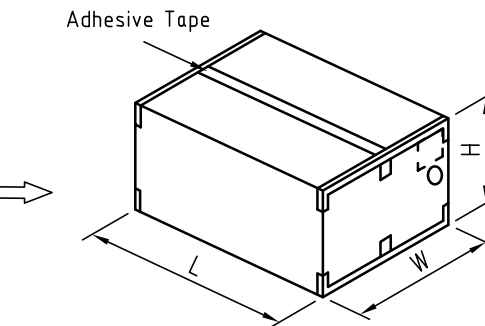
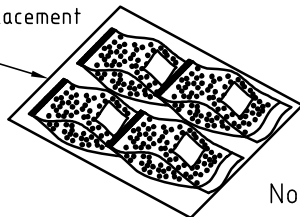

Step 3: Put PE bag packed products in cartons,
Packing detail see the table right
将装好产品的PE袋放入纸箱内, 详细包装见右表

Circuits	PCS/Bag
2x1	1000
2x2	1000
2x3	1000
2x4	1000
2x5	1000
2x6	500
2x7	500
2x8	500
2x9	500
2x10	250
2x11	250
2x12	250

Note注解:

1. There shall be no dirt such as deformation phenomenon, Mantissa box fillers must be used
每箱不可有脏污, 变形现象, 尾数箱必须用填充物
2. Confirm whether the inner and outer labels are missing and the content must be consistent with the actual product
确认内外标签有无漏失, 内容与实物必须一致
3. Packing quantity per carton depends on order and delivery quantity
每箱包装数量依订单及交货数量而定

	SPEC.	Remark
Carton 1	L460mm×W460mm×H510mm	Use the appropriate carton size according to the actual order quantity 根据实际订单数量使用合适的纸箱尺寸
Carton 2	L500mm×W500mm×H305mm	
Carton 3	L580mm×W580mm×H320mm	



MARK

1

2

3

4

5

6

7

8

9

TOLERANCE
X.X ±0.30
X.XX ±0.20
X.XXX ±0.10
Angle ±2°

TITLE:
MX3.0 DIP 180°
Wafer Dual Row
Packing

UNIT: mm SCALE: N/A

DRAWN: Arvin 2020.03.05
CHECKED:
APPROVED:

SHEET: 1/1 PROJECTION

KONNRA 东莞市康瑞电子有限公司
DongGuan Konnra Electronics Co., Ltd.
PART NO.: C3000VD2****T0101PA

REV.: A1 DRAWING NO.: 3000WD201-A-P

RoHS COMPLIANT

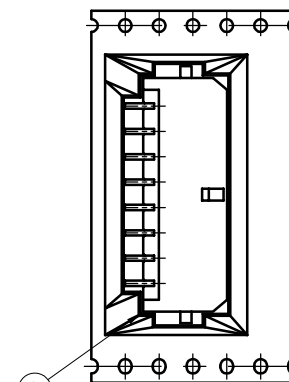
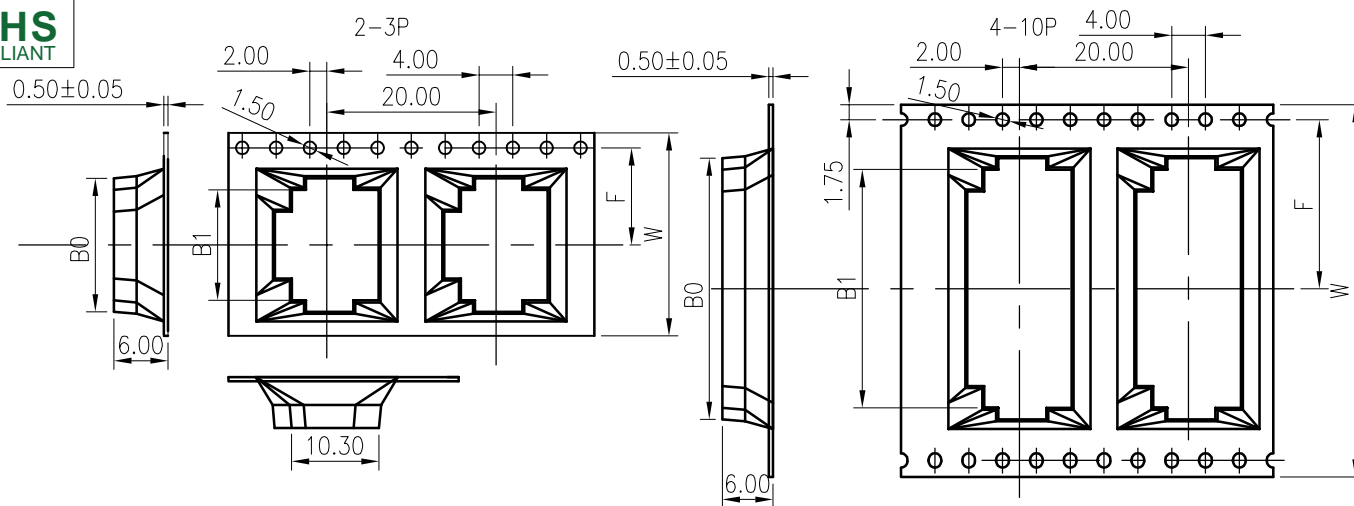

包装示意图

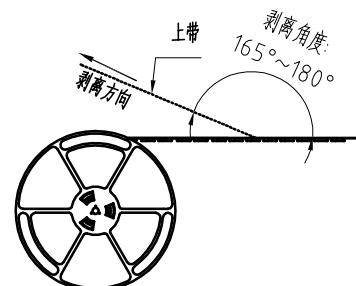
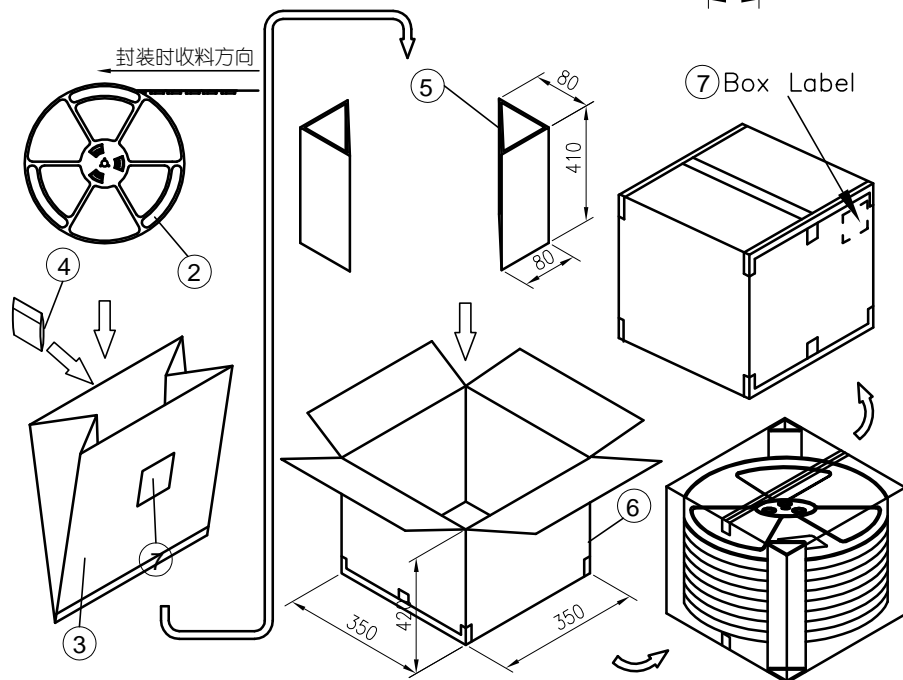

包装方式:

- 产品按要求放入载带卷盘(参考《产品卷带包装对照表》),需测试上带剥离力(剥离角度: 165°~180°; 剥离速度: 300±10mm/min);
1.1 W=12~56,剥离力0.1N~1.3N;
1.2 W=72以上,剥离力0.1N~1.5N;
- 产品卷盘包装后,进行抽真空作业(每袋内装入1PCS干燥剂),依要求贴上标签;
- 将三角纸板放入纸箱固定,再将真空包装好的产品放入纸箱内,之后用胶带封箱,并在外箱相应位置贴上标签(若卷盘数量不够整箱,纸箱和三角板高度依实际包装量修剪或填充).

CTK.	DIMENSIONS				Q'ty/BOX
	W	F	B0±0.3	B1±0.3	
2P	24.0	11.50	12.80	10.10	14*500
3P	24.0	11.50	15.80	13.10	14*500
4P	32.0	14.20	18.80	16.10	11*500
5P	44.0	20.20	21.90	19.20	8*500
6P	44.0	20.20	24.90	22.20	8*500
7P	44.0	20.20	27.90	25.20	8*500
8P	44.0	20.20	30.90	28.20	8*500
9P	56.0	26.20	33.90	31.10	6*500
10P	56.0	26.20	36.90	34.20	6*500
11P	56.0	26.20	39.90	37.20	6*500
12P	72.0	34.20	42.90	40.20	5*500

NO.	NAME	SPEC.	Q'TY
①	PRODUCT	MX3.0 SMT 90°WF焊片式系列	参照上表(特殊除外)
②	卷盘/载带	--	1SET
③	透明真空袋	500×440×0.10mm	1PCS/Reel
④	干燥剂	--	1PCS/Reel
⑤	三角纸板	410×80×80mm	2PCS
⑥	纸箱	350×350×420mm	1PCS
⑦	标签	--	2PCS

F	△4				TOLERANCE	TITLE:	DRAWN:	KONNRA 东莞市康瑞电子有限公司 DongGuan Konnra Electronics Co., Ltd. PART NO.: C3000RS1**14MD101RA					
	△3				X.X ±0.30	MX3.0 SMT 90° Wafer	CHECKED:				Arvin 2020.03.05		
	△2				X.XX ±0.20	单排焊片式	APPROVED:						
MARK	REVISION DESCRIPTION	SIGNATURE	DATE	Angle ±2°	UNIT: mm	SCALE: N/A	SHEET: 1/1	PROJECTION	REV.: A1	DRAWING NO.: 3000WHS101-A-P			

1 2 3 4 5 6 7 8 9

RoHS COMPLIANT

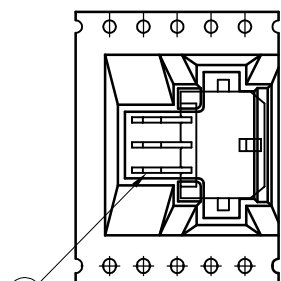
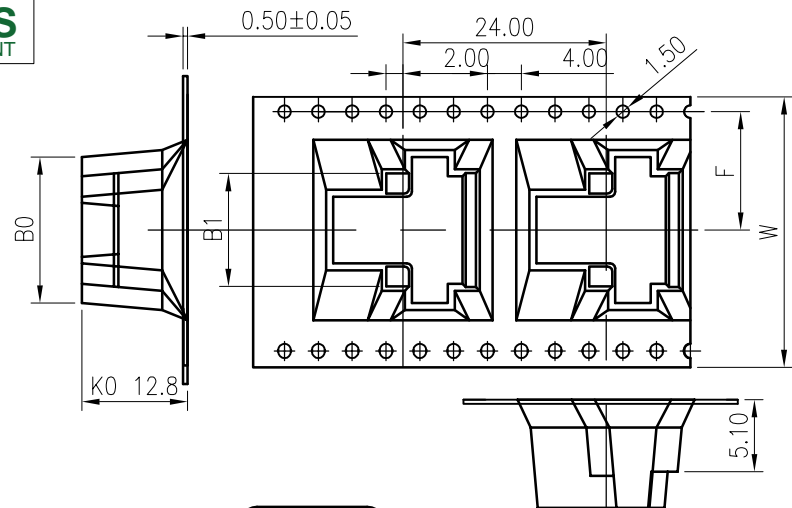

① 包装示意图-焊片式

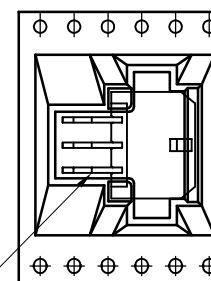

① 包装示意图-鱼叉式

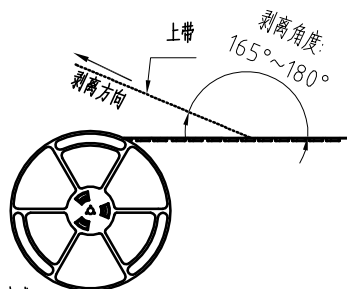
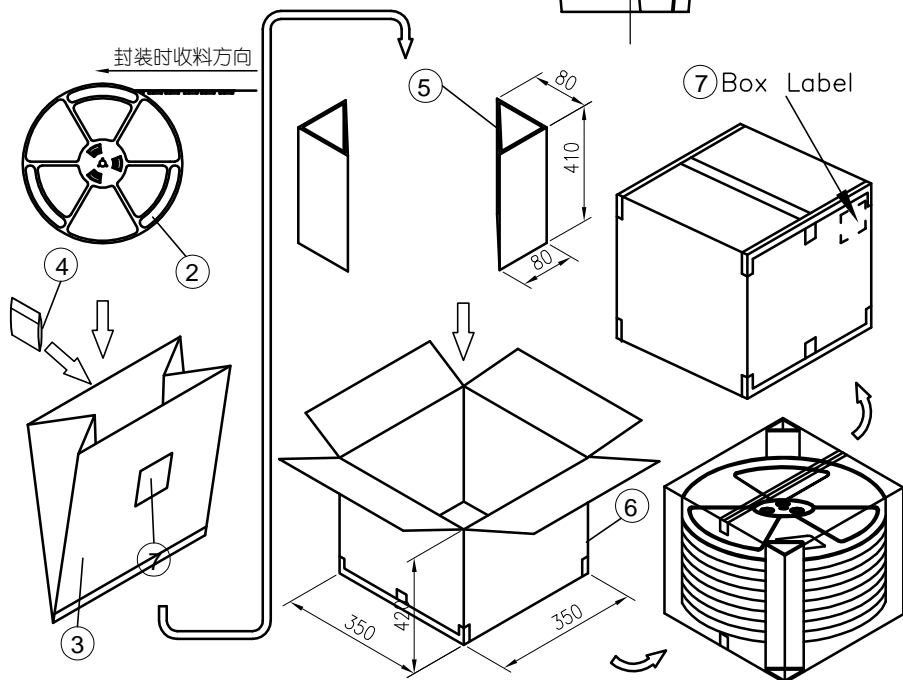

包装方式:

- 产品按要求放入载带卷盘(参考《产品卷带包装对照表》),需测试上带剥离力(剥离角度: 165~180°; 剥离速度: 300±10mm/min):
1.1 W=12~56,剥离力0.1N~1.3N;
1.2 W=72以上,剥离力0.1N~1.5N;
- 产品卷盘包装后,进行抽真空作业(每袋内装入1PCS干燥剂),依要求贴上标签;
- 将三角纸板放入纸箱固定,再将真空包装好的产品放入纸箱内,之后用胶带封箱,并在外箱相应位置贴上标签(若卷盘数量不够整箱,纸箱和三角板高度依实际包装适量修剪或填充.

CTK.	DIMENSIONS				Q'ty/BOX
	W	F	B0±0.3	B1±0.3	
2*1P	24.0	11.50	11.0	7.05	14*200
2*2P	32.0	14.20	14.0	10.05	10*200
2*3P	32.0	14.20	17.0	13.35	10*200
2*4P	44.0	20.20	20.5	16.35	8*200
2*5P	44.0	20.20	23.0	19.05	8*200
2*6P	44.0	20.20	26.0	22.05	8*200
2*7P	44.0	20.20	29.0	25.05	8*200
2*8P	56.0	26.20	31.8	28.05	7*200
2*9P	56.0	26.20	34.8	31.05	7*200
2*10P	56.0	26.20	37.8	34.05	7*200
2*11P	56.0	26.20	40.8	37.05	7*200
2*12P	72.0	34.20	44.2	40.30	5*1000

NO.	NAME	SPEC.	Q'TY
①	PRODUCT	MX3.0 SMT 90°WF焊片/鱼叉式	参照上表(特殊除外)
②	卷盘/载带	--	1SET
③	透明真空袋	500×440×0.10mm	1PCS/Reel
④	干燥剂	--	1PCS/Reel
⑤	三角纸板	410×80×80mm	2PCS
⑥	纸箱	350×350×420mm	1PCS
⑦	标签	--	2PCS

MARK	REVISION DESCRIPTION	SIGNATURE	DATE
A4			
A3			
A2			

TOLERANCE	TITLE:
X.X ±0.30	MX3.0 SMT 90° Wafer
X.XX ±0.20	双排 焊片/鱼叉式
X.XXX ±0.10	卷装包装规范
Angle ±2°	

DRAWN:	CHECKED:	APPROVED:
Arvin 2020.03.05		
SHEET: 1/1	PROJECTION	

KONNRA 东莞市康瑞电子有限公司	
DongGuan Konnra Electronics Co., Ltd.	
PART NO.: C3000RS2**14M1**R*	
REV.:	DRAWING NO.:
A1	3000WHS201-* -P

F

F

1 2 3 4 5 6 7 8 9

RoHS
COMPLIANT

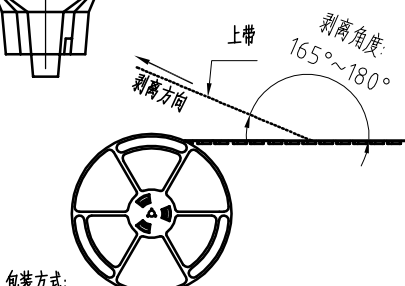
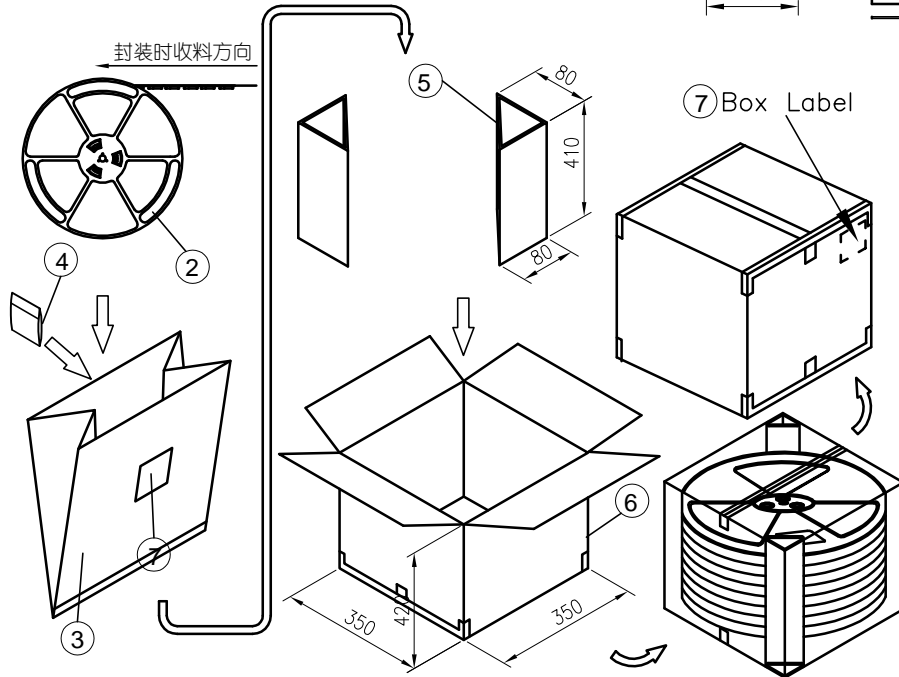
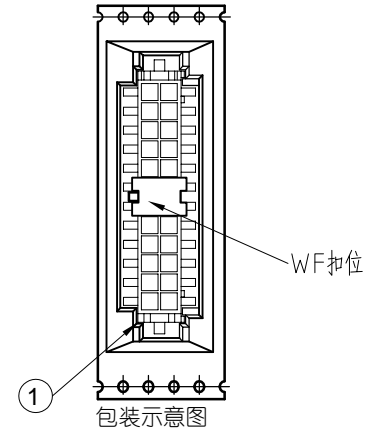
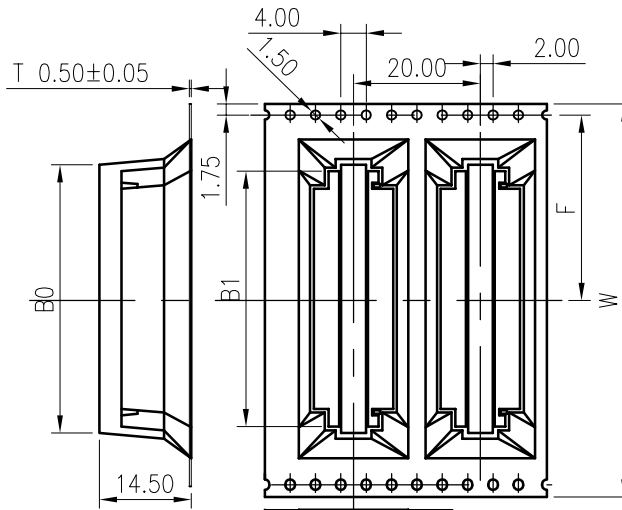
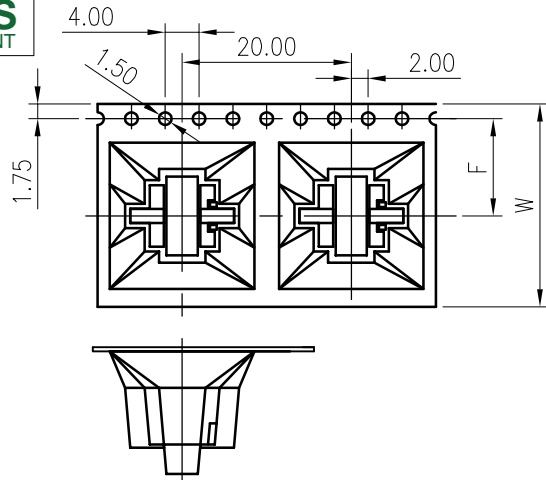

- 包装方式:
- 产品按要求放入载带卷盘(参考《产品卷带包装对照表》),需测试上带剥离力(剥离角度: 165~180°; 剥离速度: 300±10mm/min):
1.1 W=12~56,剥离力0.1N~1.3N;
1.2 W=72以上,剥离力0.1N~1.5N;
 - 产品卷盘包装后,进行抽真空作业(每袋内装入1PCS干燥剂),依要求贴上标签;
 - 将三角纸放入纸箱固定,再将真空包装好的产品放入纸箱内,之后用胶带封箱,并在外箱相应位置贴上标签(若卷盘数量不够整箱,纸箱和三角板高度依实际包装适量修剪或填充.

CTK.	DIMENSIONS				Q'ty/BOX
	W	F	B0±0.3	B1±0.3	
2*1P	24.0	11.50	9.30	7.30	14*200
2*2P	32.0	14.20	12.30	10.30	10*200
2*3P	32.0	14.20	15.30	13.30	10*200
2*4P	44.0	20.20	18.30	16.30	8*200
2*5P	44.0	20.20	21.30	19.30	8*200
2*6P	44.0	20.20	24.30	22.30	8*200
2*7P	44.0	20.20	27.30	25.30	8*200
2*8P	44.0	20.20	30.30	28.20	8*200
2*9P	56.0	26.20	33.30	31.20	6*200
2*12P	72.0	34.2	42.30	40.30	5*200

NO.	NAME	SPEC.	Q'TY
①	PRODUCT	MX3.0 SMT 180°WF焊片/鱼叉式	参照上表(特殊除外)
②	卷盘/载带	--	1SET
③	透明真空袋	500×440×0.10mm	1PCS/Reel
④	干燥剂	--	1PCS/Reel
⑤	三角纸板	410×80×80mm	2PCS
⑥	纸箱	350×350×420mm	1PCS
⑦	标签	--	2PCS

F	△4				TOLERANCE	TITLE:	DRAWN: Arvin 2020.03.05	KONNRA 东莞市康瑞电子有限公司 DongGuan Konnra Electronics Co., Ltd.	
	△3				X.X ±0.30	MX3.0 SMT 180°	CHECKED:		
	△2				X.XX ±0.20	Wafer焊片/鱼叉式	APPROVED:		
MARK	REVISION DESCRIPTION	SIGNATURE	DATE	X.XXX ±0.10	Angle ±2°	UNIT: mm SCALE: N/A	SHEET: 1/1 PROJECTION	PART NO.: C3000VS2**14M1**RA	
1	2	3	4	5	6	7	8	9	